

THE Unlocker™

DESIGNED TO REMOVE BUILT TO LAST

ULTIMATE WINDOW REMOVAL TOOL

QUICK, EASY, AND EFFICIENT

INSTRUCTION MANUAL

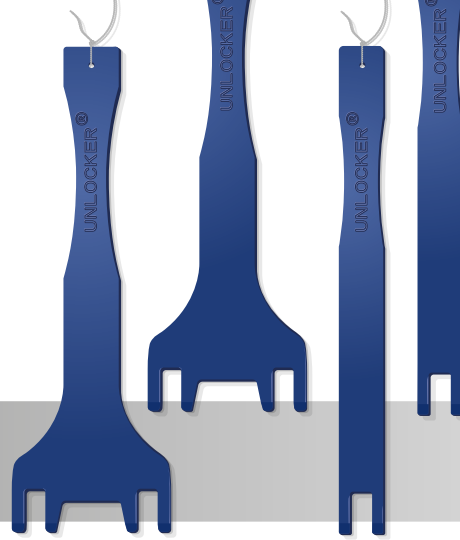

Instruction video



Interview with the inventor

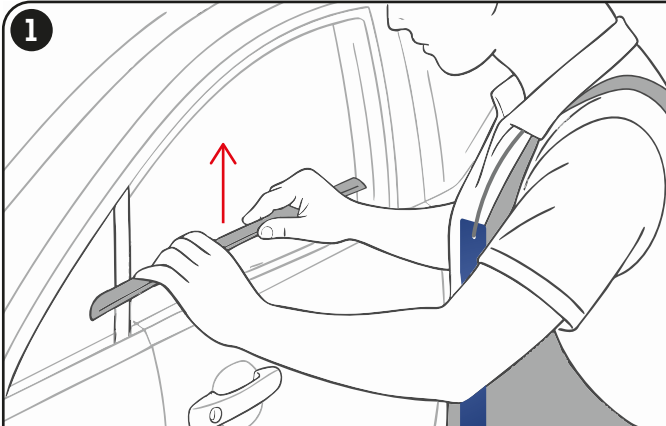

1 First, lower the window completely and remove the horizontal window trim on the outside of the car door.

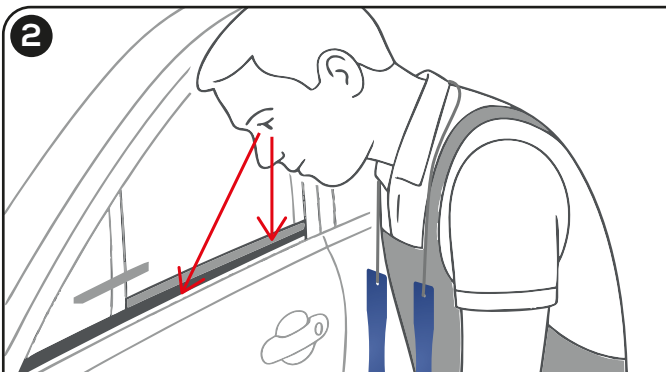

2 Raise the window fully again and look into the gap between the glass and the door at the clamps.

- Plastic clamps Use the Unlocker.
- Metal clamps Do not use the Unlocker.

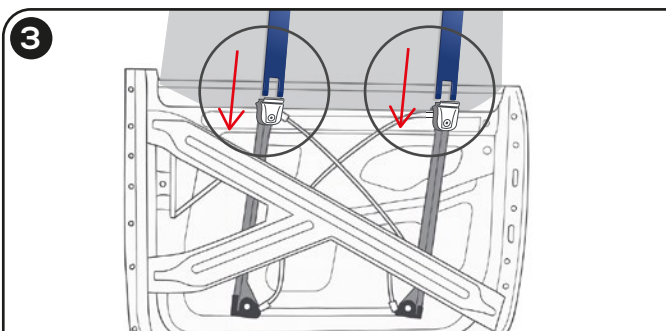

3 Lower the window about 10 cm and insert the Unlocker with the flat side along the glass, in the middle of the clamps.

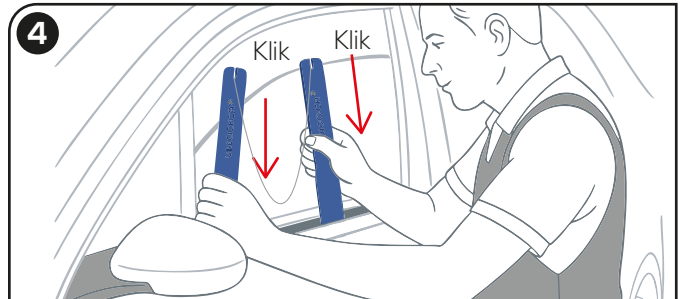

4 Now press the Unlockers down firmly until the clamps open.

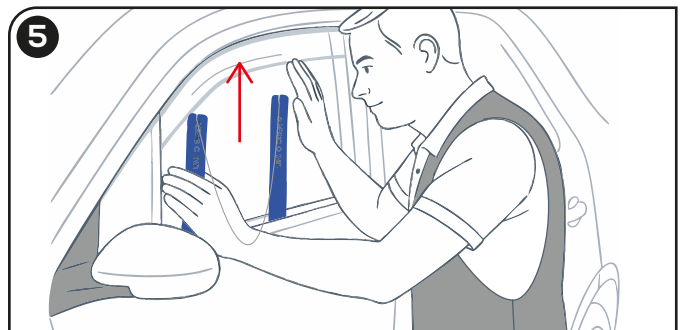

5 Slightly raise the now loose window, about 1 to 2 cm. The Unlockers can now be removed while you hold the glass in place.



6 The loose window can now carefully be lifted upward and removed from the door. After cleaning and tinting, the glass can be simply clicked back into the clamps without any tools. The window trim can then also be reinstalled.